

# KEFB Exhaust Fan

## Exhaust Fan Belt Drive

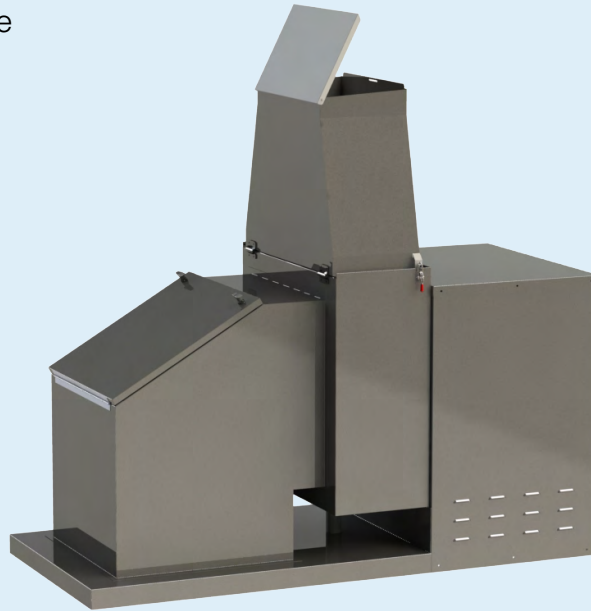

- Size ranges from 11" through 22" wheels
- Performance up to 10,000 CFM at 4.0" SP
- Testing and Balancing Ports (TAB) for ease of commissioning
- All stainless steel construction
- Extra belt inside motor cabinet
- Gravity backdraft damper
- Energy-efficient single width, single inlet welded aluminum plenum fan
- External grease collection device
- Conventional exhaust duct termination at top of curb
- Real-time airflow measurement for seamless integration with the Halton M.A.R.V.E.L. system
- Heavy-duty latches and hinges standard
- Optional roof curb available

Halton Model KEFB commercial kitchen exhaust fan can drain to a grease cup on the roof or to an exhaust duct to effectively contain grease and rainwater, mitigating contamination of the roof and the environment. This effective grease management system also meets the new requirements of many municipalities for stormwater control in commercial kitchens.

**Institutional:** The standard sealed construction belt drive KEFB with VFD controls and energy-saving backdraft damper provide an energy-efficient and reliable system that is extremely easy to maintain.

**Heavy Grease:** The liquid-tight welded KEFB designs is ideal for heavy grease applications.

The KEFB is designed specifically for compatibility with M.A.R.V.E.L. variable volume control platform and Capture Jet™ series of hoods.

**Installations with Special Environmental Requirements:** All KEF exhaust fans can be fitted with discharge extensions to clear roof parapets or other obstructions and eliminate re-entrainment of the exhaust plume.

The KEFB is listed to the following standards:

- UL 705:2017 Ed.7+R:13Feb2018 Power Ventilators including Supplement SC Power Roof Ventilators for Restaurant Exhaust Appliances (formerly UL Subject 762)
- ULC S645:1993 Ed.1 Standard For Power Roof Ventilators For Commercial And Institutional Kitchen Exhaust Systems
- CSA C22.2#113:2018 Ed.11 Fans And Ventilators

# KEFB DIMENSIONS

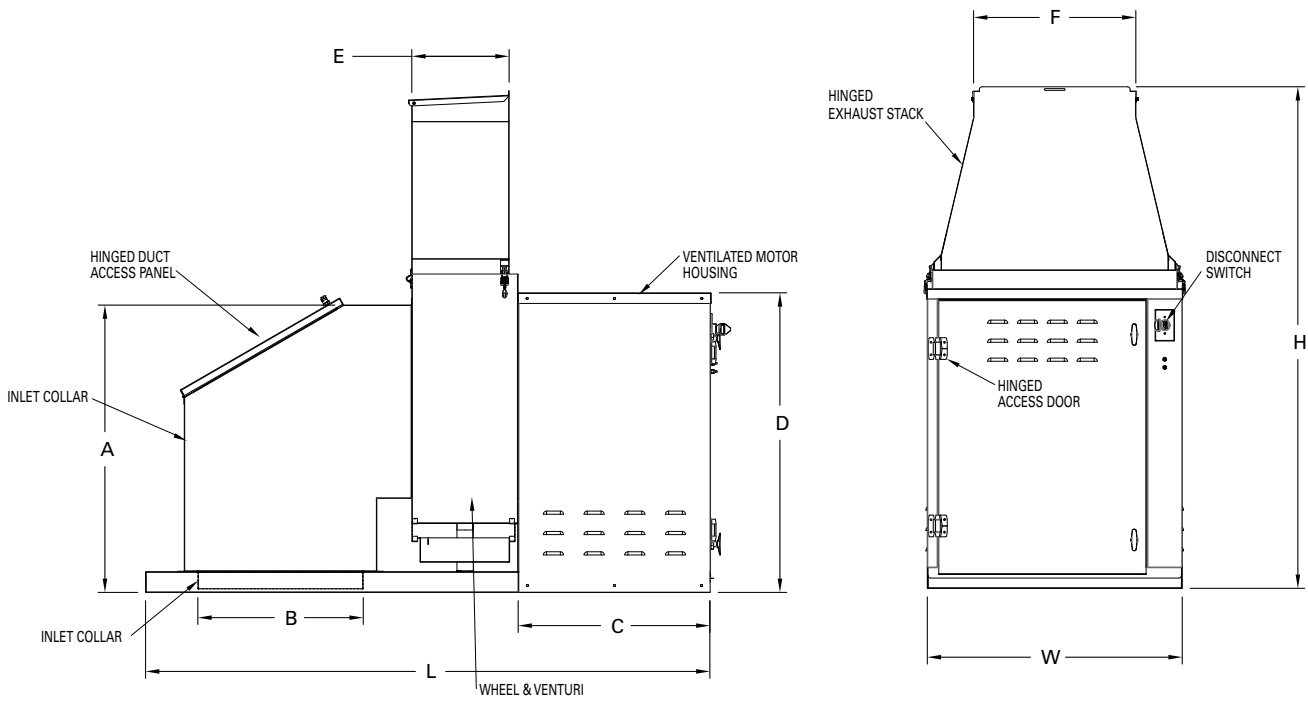

Form#: SS196\_KEFB\_Exhaust Fan  
Date: 02-2021 - Rev5

## Dimensions in **inches**

	L	W	H	A	B	C	D	E	F
KEFB-11	43.0	20.75	44.33	24.32	11.0	15.77	23.25	6.6	8.5
KEFB-14	53.0	25.0	49.02	29.39	15.0	17.32	30.96	8.18	12.15
KEFB-16	57.0	26.5	54.38	31.79	16.0	18.8	35.05	9.34	13.13
KEFB-18	66.5	29.5	59.43	34.93	19.0	21.05	36.37	10.23	16.07
KEFB-20	68.5	33.25	66.1	37.4	20.0	21.1	39.4	12.2	19.6
KEFB-22	82.0	37.0	72.8	41.7	24.0	27.8	43.5	14.1	23.6

## Dimensions in **millimeters**

	L	W	H	A	B	C	D	E	F
KEFB-11	1092.2	527.05	1125.98	617.73	279.4	400.56	590.55	167.64	215.9
KEFB-14	1346.2	635	1245.11	746.51	381.0	439.93	786.38	207.77	308.61
KEFB-16	1447.8	673.1	1381.26	807.47	406.4	477.52	890.27	237.24	333.50
KEFB-18	1689.1	749.3	1509.52	887.22	482.6	534.67	923.80	259.84	408.18
KEFB-20	1739.9	844.55	1678.94	949.96	508.0	535.94	1000.76	309.88	497.84
KEFB-22	2082.8	939.8	1849.12	1059.18	609.6	706.12	1104.9	358.14	599.44

## Optional Roof Curb Dimensions

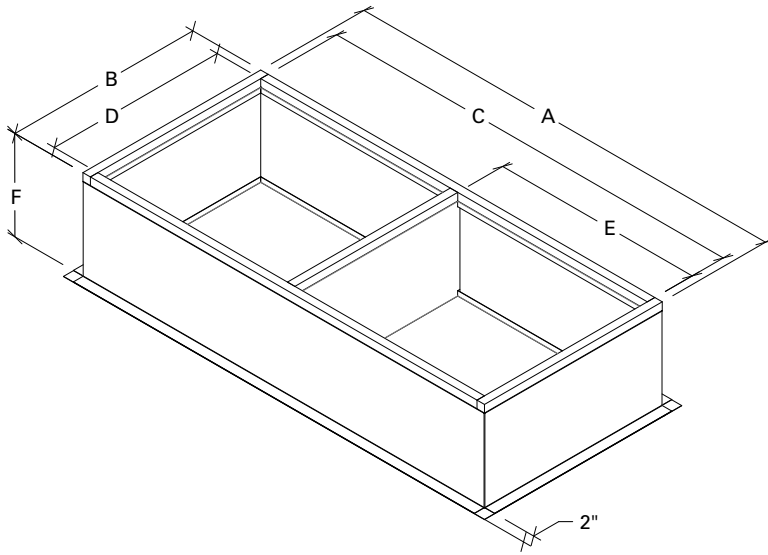

### Dimensions in **inches**

	A	B	C	D	E	F
KEFB-11	41.75	19.50	38.75	16.50	18.63	18.11
KEFB-14	51.75	23.75	48.75	20.75	23.63	18.11
KEFB-16	55.75	25.25	52.75	22.25	25.63	18.11
KEFB-18	62.25	28.25	62.25	25.25	30.38	18.11
KEFB-20	67.25	32.00	64.25	29.00	31.38	18.11
KEFB-22	80.75	35.75	77.75	32.75	38.13	18.11

### Dimensions in **millimeters**

	A	B	C	D	E	F
KEFB-11	1060.45	495.3	984.25	419.1	473.20	459.99
KEFB-14	1314.45	603.25	1238.25	527.05	600.20	459.99
KEFB-16	1416.05	641.35	1339.85	565.15	651.00	459.99
KEFB-18	1581.15	717.55	1581.15	641.35	771.65	459.99
KEFB-20	1708.15	812.8	1631.95	736.6	797.05	459.99
KEFB-22	2051.05	908.05	1974.85	831.85	968.50	459.99

# PERFORMANCE DATA

## KEFB-11 Fan Curve

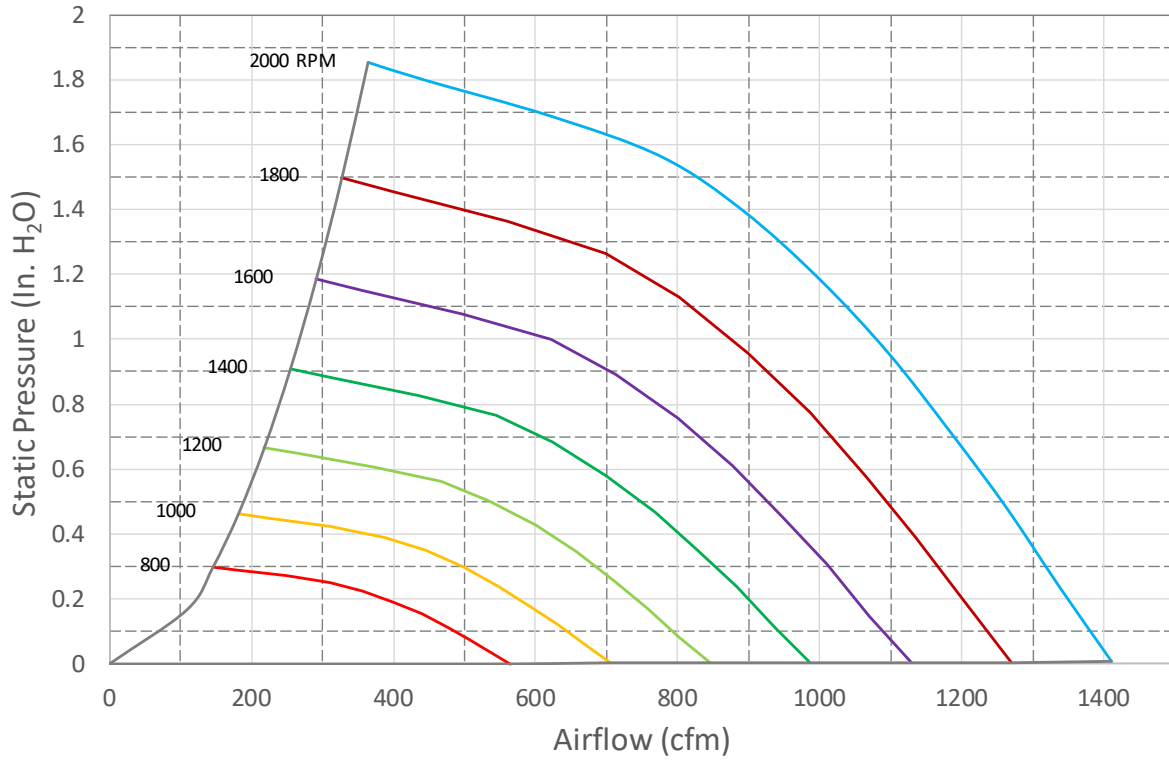

## KEFB-14 Fan Curve

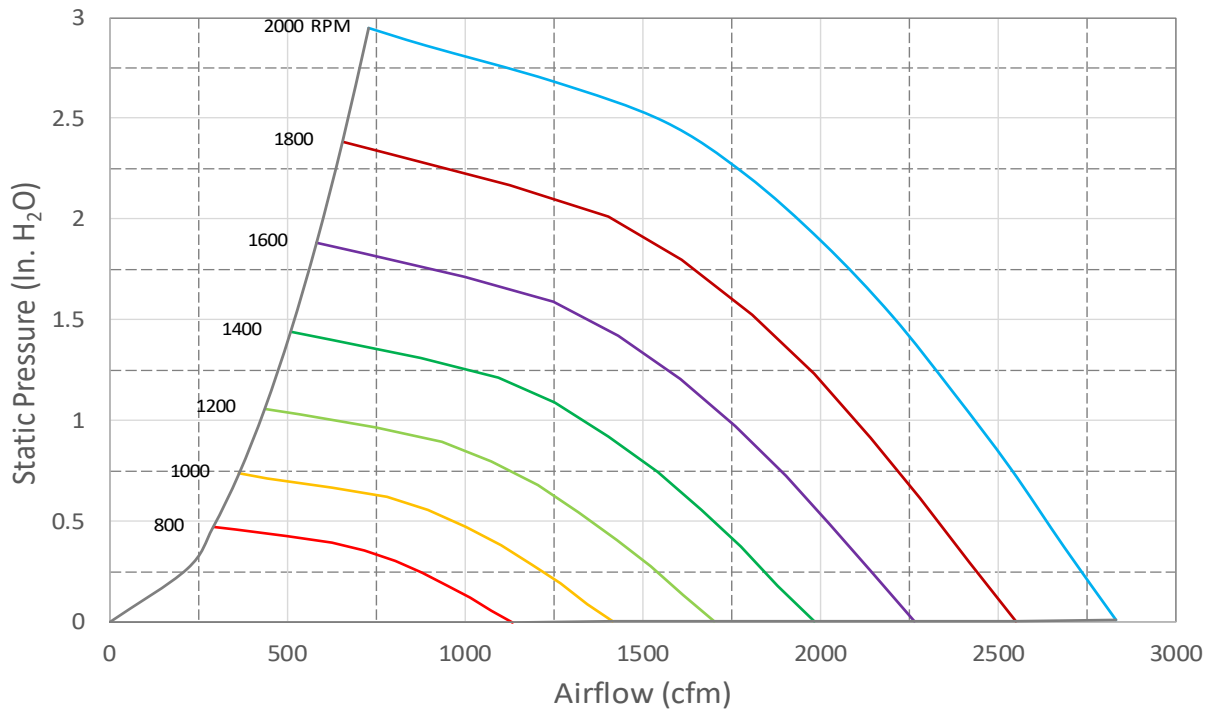

### KEFB-16 Fan Curve

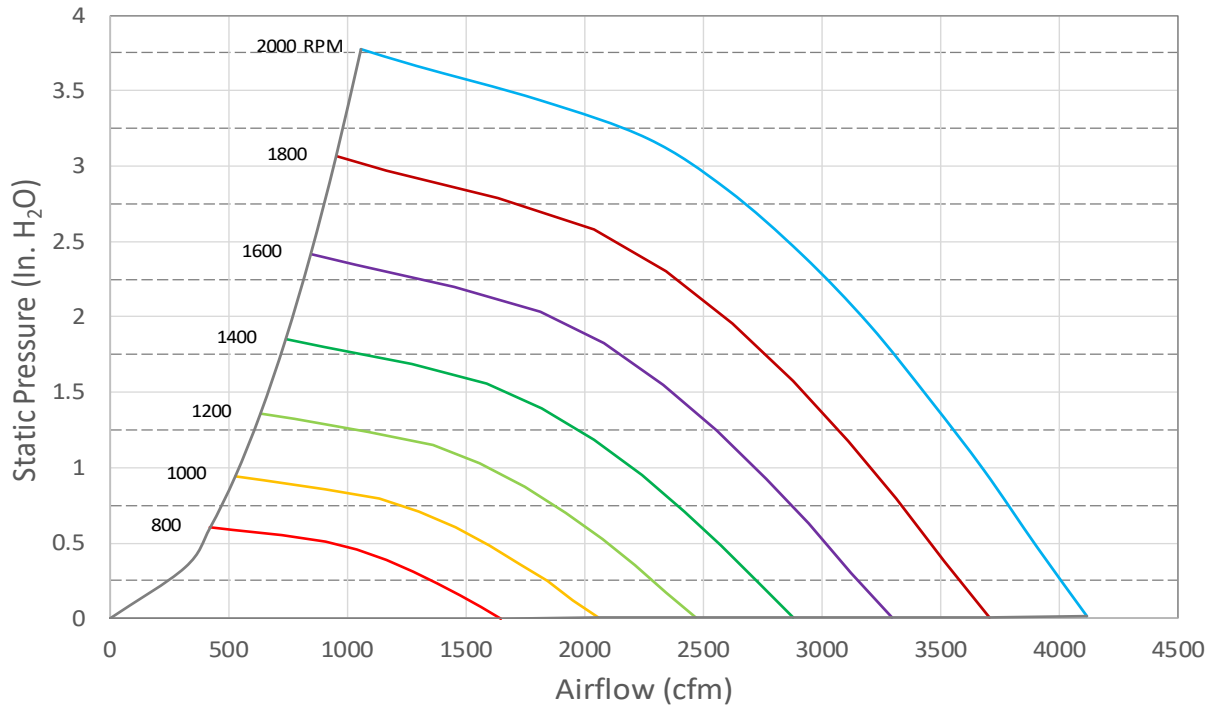

### KEFB-18 Fan Curve

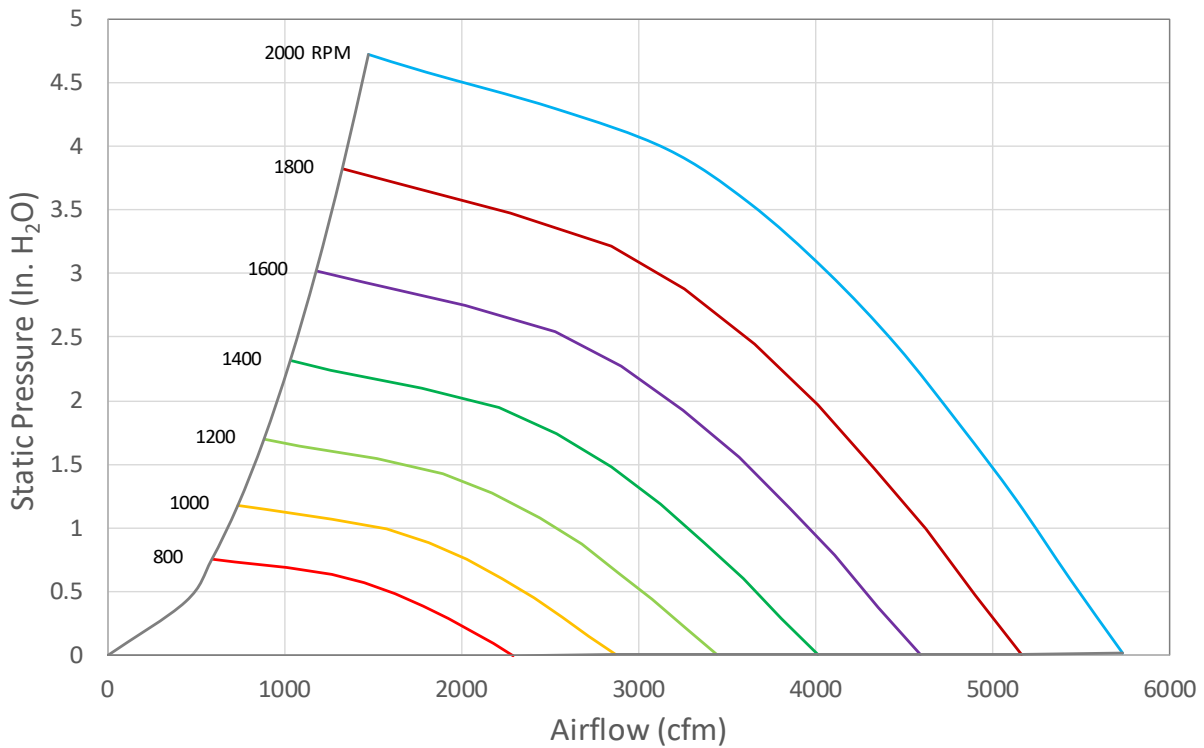

### KEFB-20 Fan Curve

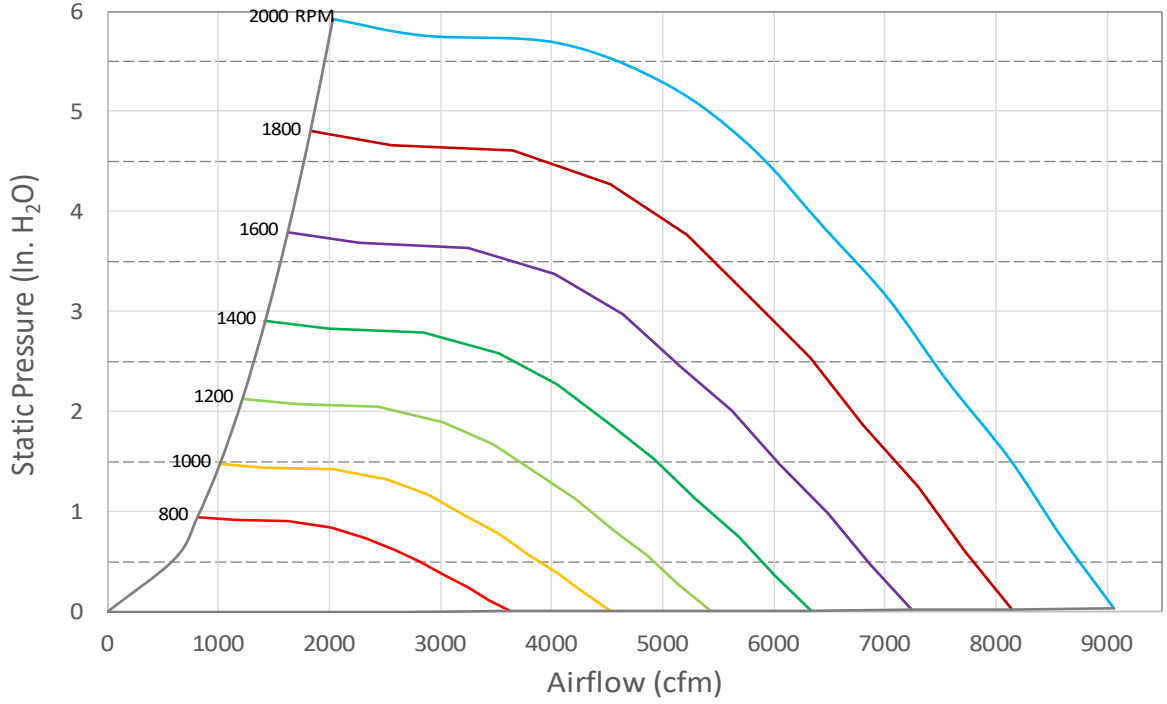

### KEFB-22 Fan Curve

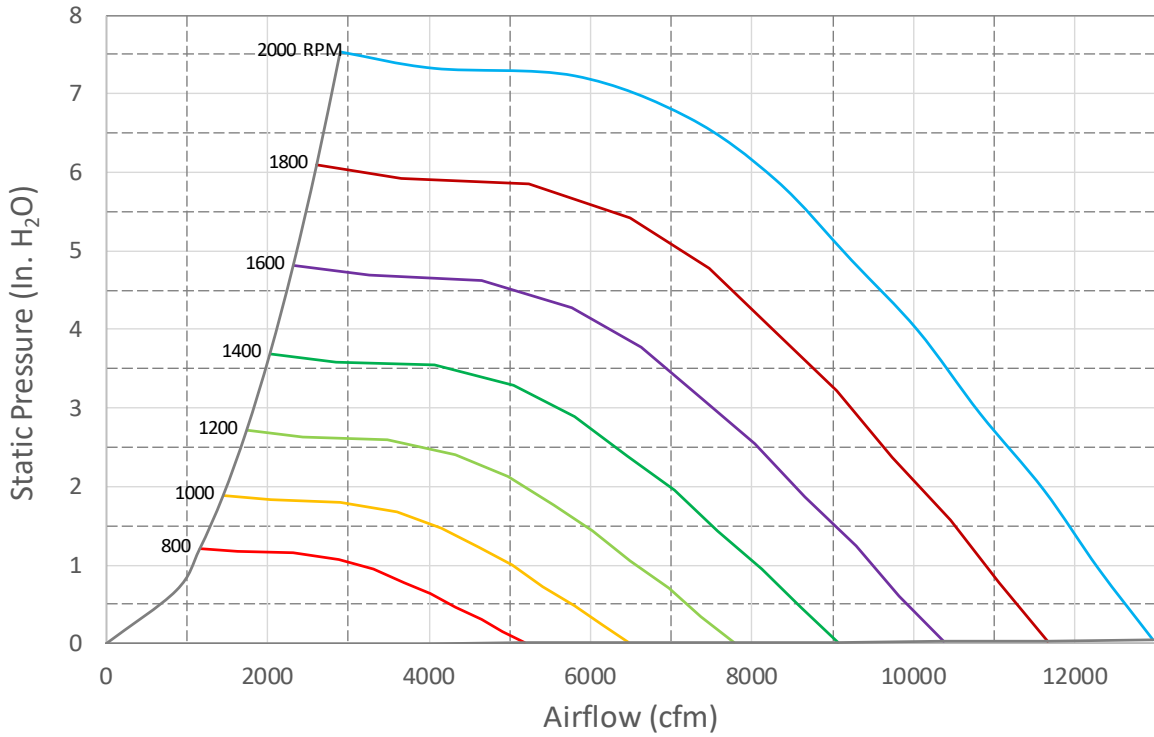

## Consultant Specification

Provide Halton Exhaust Fan Model \_\_\_\_\_, as shown on the plans and in accordance with the following specifications.

The roof exhaust fan shall be a high-velocity upblast belt type. The fan wheel shall be a single width, single inlet plenum fan of welded aluminum, and shall include a wheel cone matched to the inlet cone for precise balancing. Wheels shall be statically and dynamically balanced. The fan housing shall be constructed of 18 gauge 304 stainless steel, #2B finish, and continuously welded transition and fan housing.

Provide hinged top discharge outlet for easy access for cleaning fan wheel and wheel housing. Provide hinged access to exhaust elbow. No hinged base allowed, fan to be permanently sealed to duct termination. Provide gravity type backdraft damper

Hinged access to motor compartment for convenient access to motor and belt. Motors shall be heavy-duty ball bearing type, matched to the fan load, and furnished at the specified voltage, phase, and enclosure. Motors and drives shall be mounted on vibration isolators and out of the airstream. Include spare belt inside motor cabinet. Motor shall have a separate access door and come complete with a belt tensioner and spare belt. Drive frame assemblies shall be constructed of heavy gauge steel and mounted on vibration isolators.

Precision ground and polished fan shafts shall be mounted in permanently sealed, lubricated pillow block ball bearings. Bearings shall be selected for a minimum of (L10) life in excess of 100,000 hours at maximum cataloged operating speed. Drives shall be sized for a minimum of 150% of driven horsepower.

Pulleys shall be of the fully machined cast iron type, keyed and securely attached to the wheel and motor shaft.

VFD with non MARVEL, remote mounted as standard. NEMA rated box on fan (optional)

Standard pressure transducer standard with MARVEL control system. Non MARVEL pressure transducer output (Optional),

Optional Emergency repair kit includes inlet cone, shaft, bearing, keys, (motor optional)

A disconnect switch shall be factory installed and wired from the fan motor to a junction box installed with the motor compartment. A conduit chase shall be provided through the curb cap to the motor compartment for ease of electrical wiring.

Provide fan with integral Testing and Balancing ports for ease of commissioning.

Each fan shall bear a permanently affixed manufacturer's nameplate containing the model number and individual serial number for future identification.

Fan shall be listed to the following standards:

- UL 705:2017 Ed.7+R:13Feb2018 Power Ventilators including Supplement SC Power Roof Ventilators for Restaurant Exhaust Appliances [formerly UL Subject 762]
- ULC S645:1993 Ed.1 Standard For Power Roof Ventilators For Commercial And Institutional Kitchen Exhaust Systems
- CSA C22.2#113:2018 Ed.11 Fans And Ventilators

The company has a policy of continuous product development, therefore we reserve the right to modify design and specifications without notice.

For more information, please contact your nearest Halton agency. To find it: [www.halton.com/foodservice](http://www.halton.com/foodservice)